

Cisterna

Uso Rudo 2,500 lts

CARACTERÍSTICAS



• Diámetro	160 cm
• Altura total incluyendo tapa	163 cm
• Material	Fabricado en polietileno (HDPE)
• Certificación	NMX-C374-ONNCCCE-CNCP-2012
• Colores	 AZUL

* Las medidas pueden tener una variación de +/- 3% debido a cuestiones climáticas o ambientales.

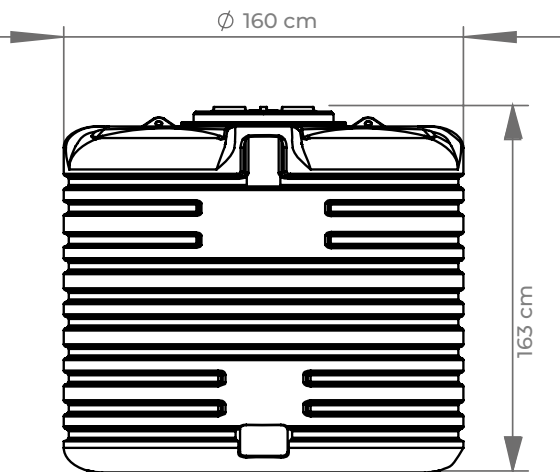

ACCESORIOS



Flotador del número 5 CITIJAL con varilla de acero



Válvula de llenado CITIJAL 1/2" - 3/4"



Multiconector



Brida de desagüe (Opcional)



Tricapa



Ultra resistencia



Antibacterial



Sellado hermético y seguro



Conserva el agua limpia



Grado alimenticio



Protección contra rayos UV



Alto nivel higiénico



Fácil y rápida instalación