

Cisterna

Citiplast 1,100 L

CARACTERÍSTICAS

· Diámetro	115 cm
· Altura total incluyendo tapa	151 cm
· Material	Fabricado en polietileno (HDPE)
· Certificación	Certificado U.S. Food and Drugs Administration (FDA) NMX-C374-ONNCCE-CNCP-2012
· Colores	 BLANCO



Recuadro para instalar brida de hasta 2" (opcional)

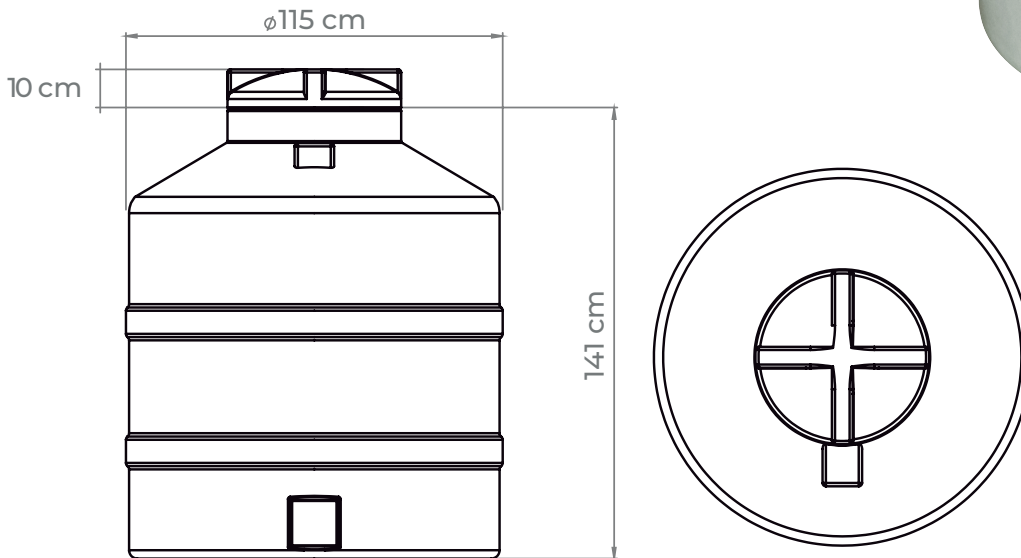

ACCESORIOS



Flotador del número 5 CITIJAL con varilla de acero



Válvula de llenado CITIJAL 1/2" - 3/4"



Protección contra rayos UV



Antibacterial



Sellado hermético y seguro



Conserva el agua limpia



Grado alimenticio



Alto nivel higiénico



Fácil y rápida instalación